

UF-TOOLS elektrický aku šroubovák 28v1, USB-C

Uživatelský manuál

Popis

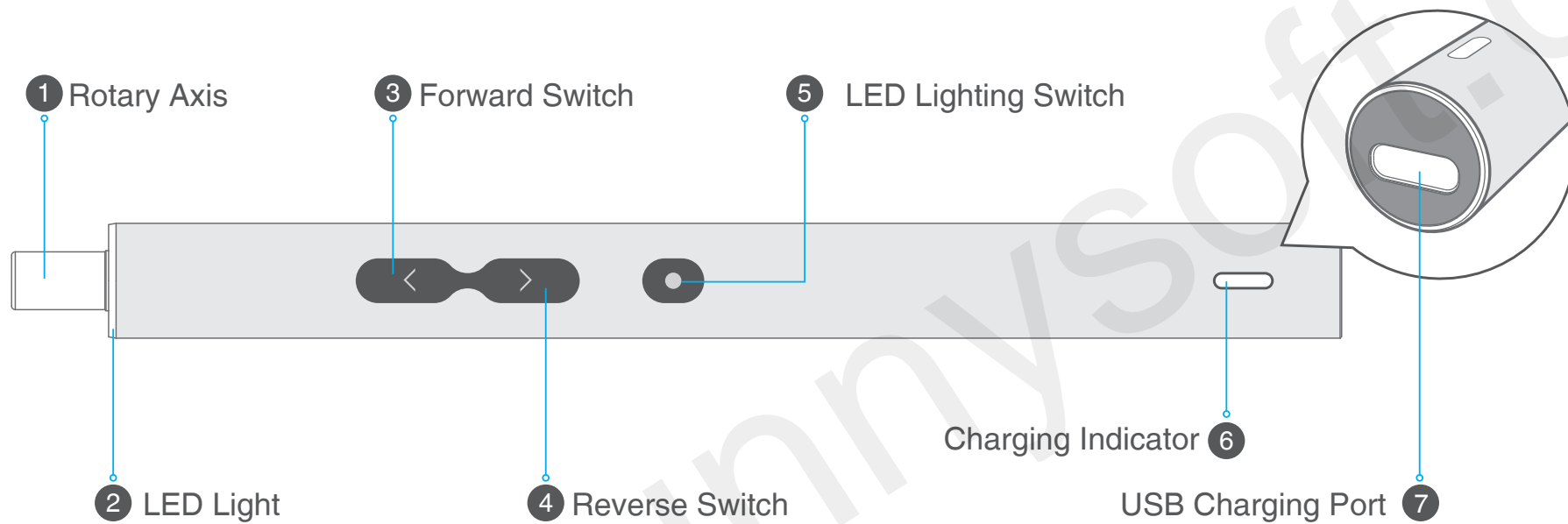

PRODUCT SPECIFICATION

- **Battery Capacity:** 350mAh
- **Voltage:** 3.7V-DC
- **Free Speed:** 300r/min
- **Charging Time:** <70mins
- **Battery Type:** Li Battery
- **Electric Torque:** 0.3-0.45Nm
- **Manual Torqye:** 3Nm
- **Net Weight:** 256g
- **Net Weight of the Screwdriver:** 58g

Screwdriver Bits: 4x28mm

- ⊕ PH000, PH00, PH0, PH1, PH2
- ⊖ SL1.5, SL2.0, SL3.0, SL4.0
- ★ T2, T3, T4
- ⊛ T5H, T6H, T8H, T10H, T15H
- ☆ P2(Pentalobe 0.8), P5(Pentalobe 1.2)
- ⬠ H1.5, H2.0
- ▲ 2.3 ⊙ U2.6 ⊙ Y1

USING STEPS

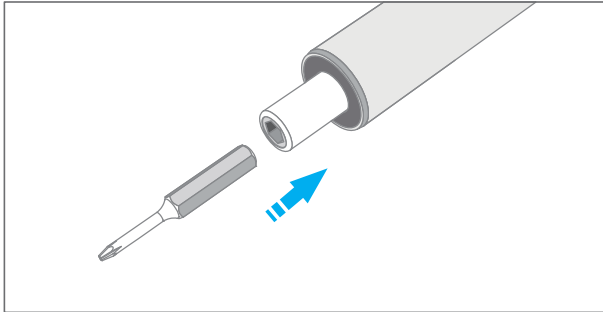

1. Install bit

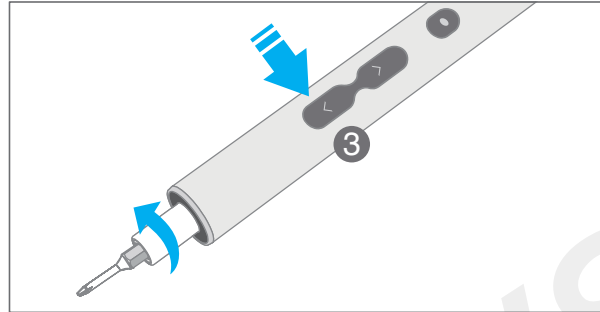

2. Press ③ , tighten the screws.

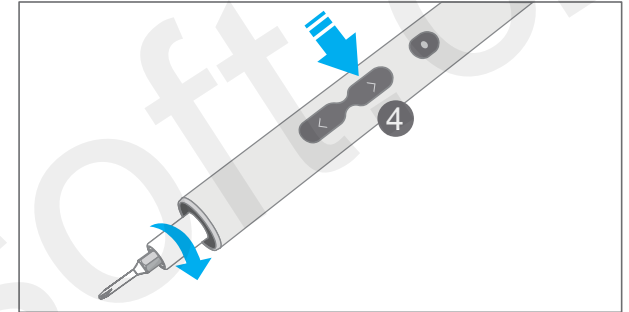

3. Press ④ , loosen the screws.

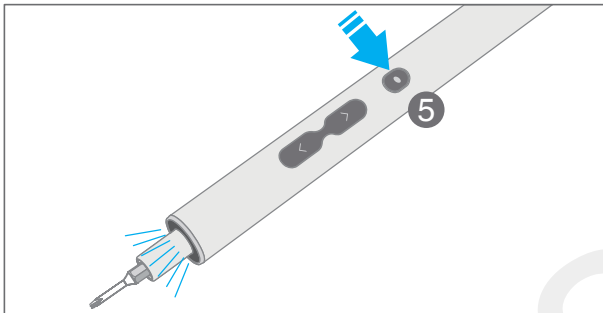

4. Press ⑤ , turn on the light, Press again, turn off the light.

5. There is a Type-C USB charging port at the end of the screwdriver.

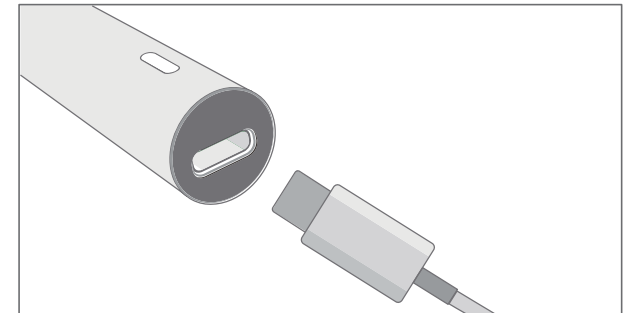

CHARGING INSTRUCTION

When using the Type-C USB charging port, the charging indicator shows red means “ charging ”, shows green means “ full charge ”.

1. Please charge the screwdriver fully and the charging time is no more than 2.5 hours before when the screwdriver the first time.
2. Please charge the screwdriver at lease once a month to maintain a good performance.
3. Only charge the screwdriver by using the provided charging cable.

SAFETY WARM TIP

Warning! Please read all the provided safety warm tips, specifications, pictures and provision.

Electrical Safety

1. lease charge the screwdriver by using the provided charging accessories, don's use others, for reduce the risk when charging.
2. Please don't put screwdriver expose under the sun or in the wet situation.

3. If you can't avoid putting the screwdriver in the wet situation, please wear the silicone sleeves to reduce risk.
4. If using the electric screwdriver in the electrostatic environment, install an electrostatic ring to demagnetize the driver bits to reduce operation accidents.

Personal Safety

1. There is a little dangerous of the electric screwdriver, please do not let the babies or children use it to avoid injury.
2. Please don't put it in the pockets or bags to avoid operate the electric screwdriver accidentally causing injury.
3. When operating the electric screwdriver, the holding height could not be too high or too low ensure that the electric screwdriver can be controlled under other external force.

Using Precaution

1. When using the electric screwdriver to remove screws, please use the manual mode to loosen the screws avoid destroy screws and other parts at screws.
2. When not using the electric screwdriver, please put it out of the reach of the children.
3. If the product falls into the water or splashes into the machine, please stop using it to avoid short circuit.

4. When maintain the electric screwdriver, please check the smoothness of the screwdriver head rotation, whether other parts are damaged, etc. If there are some damages, please repair it before using. Using the damaged electric screwdriver may cause accident.
5. When the fastener or the hidden wire operation may be touched, the electric screwdriver should be held by the holding surface of the insulator.
6. Don't disassemble this product.
7. Please follow the instructions.

Maintenance

1. Ask professional maintenance staffs to use the same spare parts to repair the electric screwdriver. This will ensure the safety of the electric screwdriver being repaired.
2. Never repair the damaged battery pack. The battery pack just could be repaired by the producer or the authorized service providers.